

# George W Ferris

## F-TF.B.5

Perhaps you have enjoyed riding on a Ferris wheel at an amusement park. The Ferris wheel was invented by George Washington Ferris for the 1893 Chicago World's Fair.

Carlos, Bethany and their friends are celebrating the end of the school year at a local amusement park. Carlos has always been afraid of heights, and now his friends have talked him into taking a ride on the amusement park Ferris wheel. As Carlos waits nervously in line he has been able to gather some information about the wheel. By asking the ride operator, he found out that their wheel has a radius of 25 feet and its center at 30 feet above the ground. With this information, Carlos is trying to figure out how high he will be at different positions on the wheel.

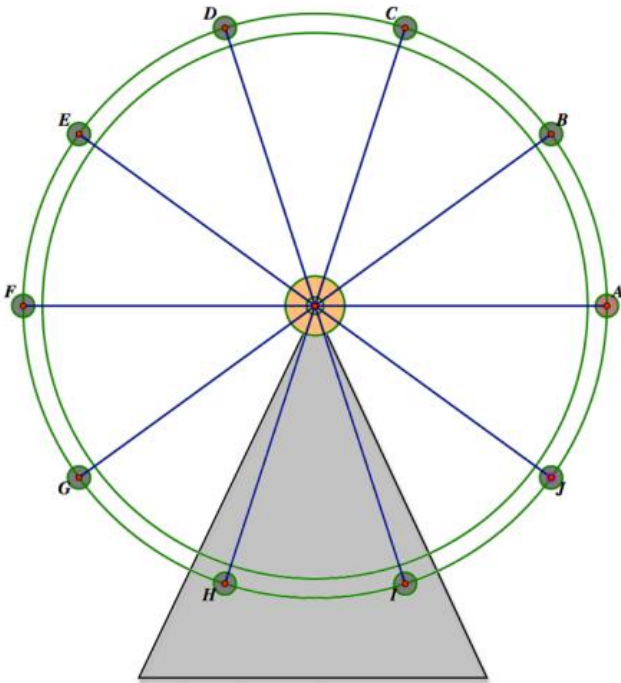

1. At what height will Carlos be when he is at the top of the wheel?
2. At what height will Carlos be when he is at the bottom of the wheel?
3. At what height will Carlos be when he is at the positions farthest to the left or the right on the wheel?
4. Find the height of each of the points on the Ferris wheel diagram. Represent your work so that it is apparent to others how you have calculated each height.

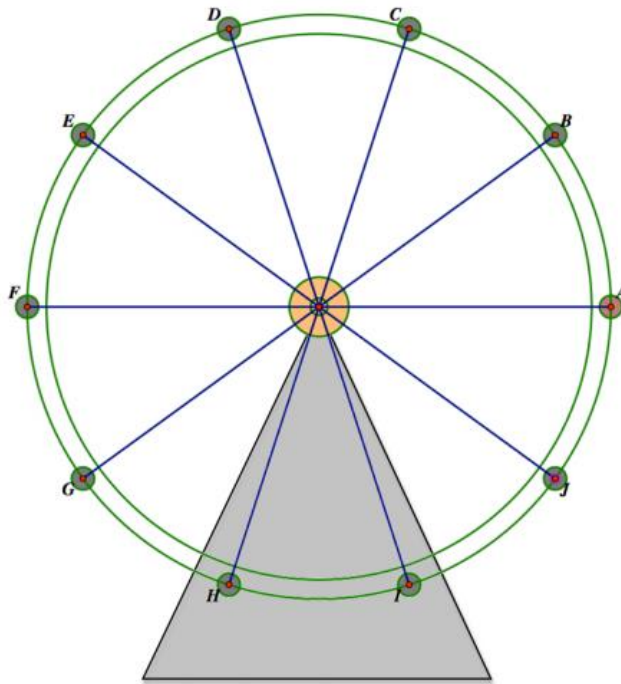

Carlos has also been carefully timing the rotation of the wheel and has observed that this Ferris wheel makes one complete rotation counterclockwise every 20 seconds.

1. What will Carlos' height be 2 seconds after passing position A on the diagram?

Calculate the height of a rider at each of the following times  $t$ , where  $t$  represents the number of seconds since the rider passed position A on the diagram.

Elapsed Time Since Passing Position A	Height of the Rider
1 sec	
1.5 sec	
2 sec	
2.5 sec	
3 sec	
4 sec	
5 sec	
6 sec	
7 sec	
8 sec	
9 sec	

Elapsed Time Since Passing Position A	Height of the Rider
10 sec	
11 sec	
12 sec	
13 sec	
14 sec	
15 sec	
16 sec	
17 sec	
18 sec	
19 sec	
20 sec	

Are there any generalizations that can be made based on the calculations completed?

- a. If the ride started at point A, at what times would Carlos be at the top of the Ferris wheel?
- b. At what times would Carlos be at the bottom of the Ferris wheel?
- c. At what times would Carlos be 30 feet off the ground?
- d. Assume Carlos got on the Ferris wheel at point I. The wheel got stuck 57 seconds into the ride. Should Carlos be scared? At what height is Carlos sitting at this point?

2. Based on the data you calculated, as well as any additional insights you might have about riding on Ferris wheels, sketch a graph of the height of a rider on this Ferris wheel as a function of the time elapsed since the rider passed the position farthest to the right on the Ferris wheel.

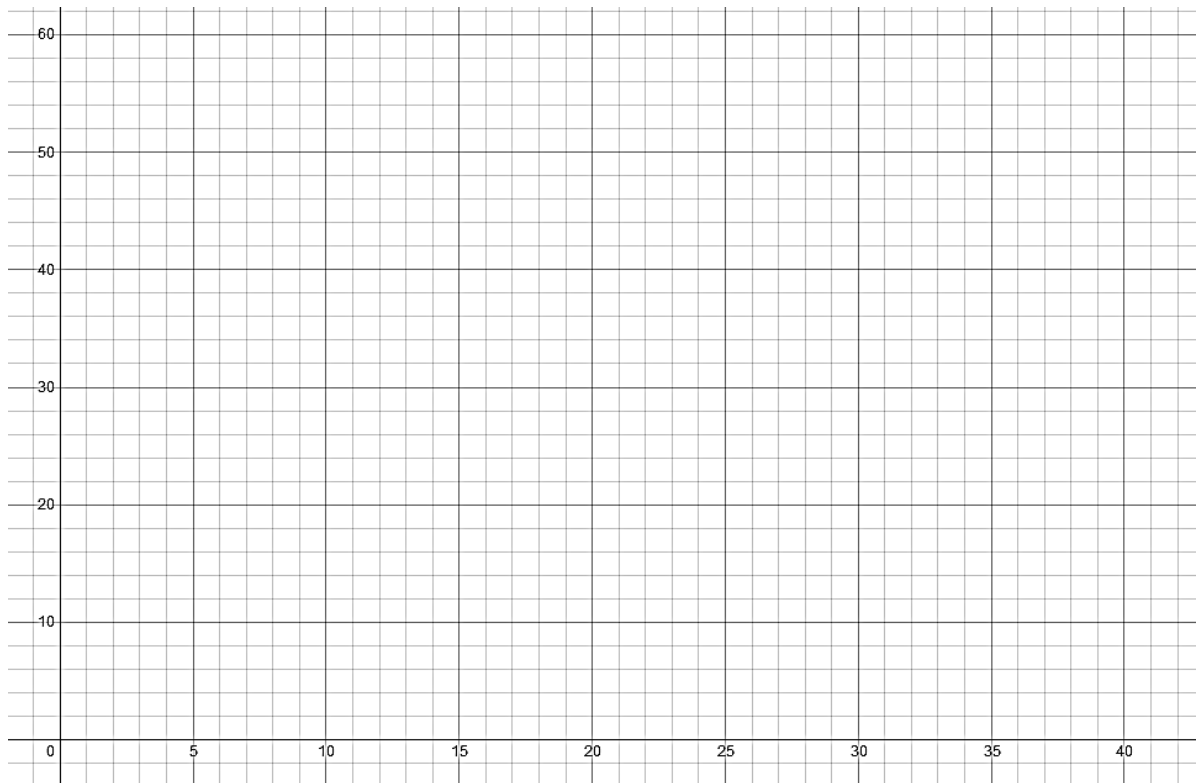

- a. What trig function helped you complete the chart on the other page?
- b. Make a rough sketch of the pattern that developed on your graph from 0 to 20 seconds. (connect the dots)  
Guess what this curve is called?

c. What do you think the graph would look like from 20 to 40 seconds?

Elapsed Time Since Passing Position A	Height of the Rider
23 sec	
28 sec	
35 sec	
36 sec	
37 sec	
40 sec	

Elapsed Time Since Passing Position A	Height of the Rider
43 sec	
48 sec	
50.5 sec	
52 sec	
55 sec	
60 sec	

3. We began this task by considering the graph of the height of a rider on a Ferris wheel with a radius of 25 feet and center 30 feet off the ground, which makes one revolution counter-clockwise every 20 seconds. How would your graph change if:

a. The radius of the wheel was larger or smaller?

b. The height of the center of the wheel was greater or smaller?

c. The wheel rotates faster or slower?